



NEW PURCHASE INFORMATION



Congratulations on the purchase of your brand-new camper. We are excited to officially welcome you to the Austrack Family. As a fellow Austracker, you join a community of passionate campers who love the outdoors and camping just as much as you do. It won't be too long before you're out there discovering and exploring Australia with them.



07 5498 3888
SALES@AUSTRACKCAMPERS.COM.AU
AUSTRACKCAMPERS.COM.AU

Congratulations on the purchase of your brand-new camper. We are excited to officially welcome you to the Austrack Family. As a fellow Austracker, you join a community of passionate campers who love the outdoors and camping just as much as you do. It won't be too long before you're out there discovering and exploring Australia with them.

In the coming pages, there is some important information that you need to be aware of before you take delivery of your new Austrack Camper.

Contents

Ordering your new Camper	3
Estimated time of delivery.....	4
Availability of componentry.....	4
Tracking your order	4
Preparing for pickup	5
Trailer Plug.....	5
Preparing your tow bar.....	6
Anderson Plug – Hybrid Camper.....	7
Anderson Plug – Camper trailer.....	7
Brake Controller.....	8
Austrack Academy	8
Servicing of your trailer.....	9

Head Office – 07 5498 388 Brisbane North – 07 5408 7111 Brisbane South – 07 3112 7868
Newcastle NSW – 02 4006 6833 Campbellfield VIC – 03 9357 5081 Kewdale WA – 08 6252 7007
Precision Motors Armidale NSW – 02 6772 5866 Rising Sun Townsville – 07 4779 0211



07 5498 3888
SALES@AUSTRACKCAMPERS.COM.AU
AUSTRACKCAMPERS.COM.AU

Ordering your new Camper

When you place the order, an invoice is raised for the deposit amount of \$1000 plus any extra's you have ordered and delivery costs if applicable. The deposit amount required is \$1000 and this is to be paid within 7 days of placing the order. The only exemptions to this are if you are financing with Austrack Finance or if you have been given an extension by the salesperson. The invoice will not be automatically cancelled if you do not pay the deposit, please see below for cancellation details.

When your camper is ready for handover, you will be called to book in a mutually suitable time. Showrooms are unable to store the camper for extended periods of time, a handover is required to be booked within 7 days of notification of arrival. Please note that showrooms cannot accommodate weekend handovers, they will be booked Mon-Fri only.

Austrack Finance can be contacted on 07 5437 6988 and can organise finance and insurance for your new camper.

When making the final payment, if paying via direct deposit, finance etc, the funds must be cleared into the Austrack Campers bank account and verified before the camper will be released to you. A bank cheque presented on the day is acceptable. Please ensure the bank cheque is made out to Auscamper Pty Ltd.

If you wish to cancel the order for any reason, please contact the showroom in which you ordered. If the deposit has been paid, you will be asked to email your bank details through to facilitate the refund. It will take 7-10 working days for the refund to be received back in your account after cancellation.

Head Office – 07 5498 388 Brisbane North – 07 5408 7111 Brisbane South – 07 3112 7868
Newcastle NSW – 02 4006 6833 Campbellfield VIC – 03 9357 5081 Kewdale WA – 08 6252 7007
Precision Motors Armidale NSW – 02 6772 5866 Rising Sun Townsville – 07 4779 0211



07 5498 3888
SALES@AUSTRACKCAMPERS.COM.AU
AUSTRACKCAMPERS.COM.AU

Estimated time of delivery

When you place your order, you are given an approx. time of delivery. This is based on previous delivery times and future planning. We will always do our best to deliver your new Austrack Camper within the timeframe given, but there can be delays that are outside our control. These delays may come down to shipping, transport, componentry availability and more.

The Austrack Campers team will do our best to update you along the way, please keep in mind due to shipping there may be periods where no update is available.

Availability of componentry

There may be occasions where the supply of a certain components is unavailable, Austrack Campers reserves the right to substitute a product to one of equal or better quality or value. This ensures that Austrack Campers can still deliver a high-quality product and meet customer demands. The substitution is at Austrack Campers discretion.

An example of this may be nil availability of the Dometic air-conditioner and therefore the need for Austrack Campers to use the Truma air-conditioner or equal or better quality/features or value.

Tracking your order

If you are within 8 weeks of your expected delivery time, and would like an update, please complete the form by scanning the QR code below.



Head Office – 07 5498 388 Brisbane North – 07 5408 7111 Brisbane South – 07 3112 7868
Newcastle NSW – 02 4006 6833 Campbellfield VIC – 03 9357 5081 Kewdale WA – 08 6252 7007
Precision Motors Armidale NSW – 02 6772 5866 Rising Sun Townsville – 07 4779 0211

Preparing for pickup

It is important that you are aware of the weight of the trailer you have purchased and the capabilities of your vehicle. It is the responsibility of the purchaser to ensure that the trailer and vehicle combination complies with all relevant laws, including weight limits. Austrack Campers may advise on the legality of the combination, but the responsibility lies with the purchaser.

The trailer is designed to accommodate transport of personal belongings, as well as water, gas, jerry cans, firewood, fridges etc. This means that when you collect the trailer, the weight distribution will not be at an ideal level. Care should be taken when travelling with an empty trailer, as this will affect the stability of the trailer, especially when travelling at speed.

The trailer requires a run-in period, especially the brake linings. For the first 500-1000kms the brake linings will not be as effective. It is important to ensure you leave sufficient space between yourself and the vehicle in front and practice defensive driving in all situations, but especially on the initial drive home.

Trailer Plug

Your Austrack Camper will be fitted with a 7-pin flat trailer plug. This will be wired as per Australian Standards, wiring diagram is below.

Pin No.	Circuit	Colour	Cable Entry View	
1	Left-Hand Turn	Yellow		
2	Reversing Signal	Black		
3	Earth Return	White		
4	Right-Hand Turn	Green		
5	Service Brakes	Blue		
6	Stop Lamps	Red		
7	Rear Lamps, Clearance & Side Marker Lamps	Brown		

Head Office – 07 5498 388 Brisbane North – 07 5408 7111 Brisbane South – 07 3112 7868

Newcastle NSW – 02 4006 6833 Campbellfield VIC – 03 9357 5081 Kewdale WA – 08 6252 7007

Precision Motors Armidale NSW – 02 6772 5866 Rising Sun Townsville – 07 4779 0211

Preparing your tow bar

The Ark XO coupling requires a specific tow tongue and ball to be installed on your vehicle to ensure the hitch can lock correctly and articulate with adequate clearance.

The coupling requires a 50mm tow ball with round shoulder and is recommended to use only the ball that is provided with the coupling. During the handover, this will be installed onto your vehicle, so please ensure that the existing tow ball is removed before arriving for your handover.

The below images show the minimum clearance required from the centre of the tow ball to the face of the tow tongue.

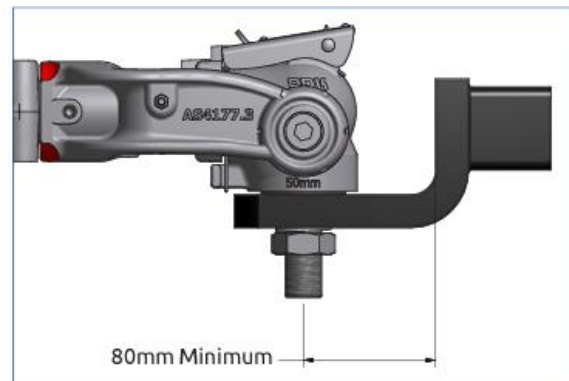
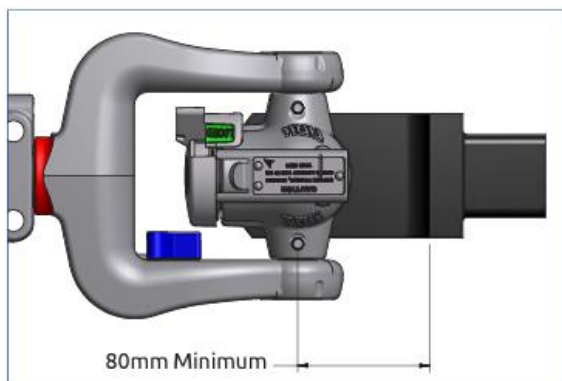

If you have ordered the Cruisemaster DO35 as an optional extra on your invoice, the hitch pin will be installed as part of your handover, please ensure that any tow balls or previous pins are removed before arriving for your handover.



07 5498 3888
SALES@AUSTRACKCAMPERS.COM.AU
AUSTRACKCAMPERS.COM.AU

Anderson Plug – Hybrid Camper

The Hybrid campers are fitted with the Redarc Manager30 which has a vehicle input to the DC-DC charger via the drawbar Anderson connection. The Manager30 Ignition trigger wire has not been connected, so if your vehicle has a smart-alternator you will need to speak with an Auto Electrician to determine the best set up for your vehicle.

The Redarc Manager30 is designed to operate with Green Power Priority, meaning that it will always prioritise the solar power above all else. You may notice that the vehicle will be showing voltage at the Redarc display screen, but not drawing any power. This means that the system is getting sufficient current from the solar panels.

The drawbar Anderson Connection is not suitable for the connection of an external solar panel due to the Manager30. There is a second Anderson Connection on the driver's side of the Hybrid, behind the wheel arch is that designed for this purpose. This Anderson connection is connected directly to battery bank, meaning that you will need to use a regulated solar panel.

Anderson Plug – Camper trailer

The Camper Trailers do not have a DC-DC charger installed, meaning that the Anderson connection on the drawbar of the trailer can be used for any regulated input source. This could be from the DC-DC charger installed in your tow vehicle or a regulated solar panel.

If you intend to charge the camper from a vehicle with a Smart-Alternator you will need to speak with an Auto Electrician to determine the best set up for your vehicle.

Head Office – 07 5498 388 Brisbane North – 07 5408 7111 Brisbane South – 07 3112 7868
Newcastle NSW – 02 4006 6833 Campbellfield VIC – 03 9357 5081 Kewdale WA – 08 6252 7007
Precision Motors Armidale NSW – 02 6772 5866 Rising Sun Townsville – 07 4779 0211

Brake Controller

All Austrack Camper models require an electronic brake controller to be installed into the tow vehicle. The brake controller will sense the braking of the tow vehicle and apply either a pre-set or proportional amount of braking current to the trailer. There are a number of options for electronic brake controllers, some being hard wired and others being Bluetooth, trailer mounted units.

Here is a link for the Redarc Tow-Pro Elite V3 that is recommended.



If you do not have an electronic brake controller installed in your tow vehicle or a Bluetooth unit to install on pickup, Austrack Campers will not be able to release the trailer to you.

Austrack Academy

Austrack Academy has been developed to consolidate all the useful videos and resources into one place. Scan the QR code below to access this resource.





07 5498 3888
SALES@AUSTRACKCAMPERS.COM.AU
AUSTRACKCAMPERS.COM.AU

Servicing of your trailer

Your Austrack Camper requires regular servicing. The first service is required at 1000km, with regular servicing every 2500kms after. A copy of the Maintenance Schedule is below, you will also be given a copy of as part of your handover paperwork.

This maintenance is highly recommended to be completed by a qualified professional. You may be asked to provide details surrounding the service history if a warranty claim is submitted.

Head Office – 07 5498 388 Brisbane North – 07 5408 7111 Brisbane South – 07 3112 7868
Newcastle NSW – 02 4006 6833 Campbellfield VIC – 03 9357 5081 Kewdale WA – 08 6252 7007
Precision Motors Armidale NSW – 02 6772 5866 Rising Sun Townsville – 07 4779 0211



Camper Maintenance Schedule

*Highlighted
Off-Road Use*

AUSTRACK CAMPERS

TANAMI HYBRID

CAMPER BRAND

MODEL/TYPE

ITEM	RECOMMENDED INTERVALS								
	3 months or 1,000km	2,500km	6 months or 5,000km	7,500km	12 months or 10,000km	12,500km	18 months or 15,000km	17,500km	24 months or 20,000km
BATTERY CONDITION	Test	Test	Test	Test	Test	Test	Test	Test	Test
LIGHTS	Test	Test	Test	Test	Test	Test	Test	Test	Test
SWITCHES	Test/Inspect	Test/Inspect	Test/Inspect	Test/Inspect	Test/Inspect	Test/Inspect	Test/Inspect	Test/Inspect	Test/Inspect
BATTERY TERMINALS/LEADS	Inspect	Inspect	Inspect	Inspect	Inspect	Inspect	Inspect	Inspect	Inspect
WATER PUMPS/HOSES	Test/Inspect	Test/Inspect	Test/Inspect	Test/Inspect	Test/Inspect/Clean	Test/Inspect	Test/Inspect	Test/Inspect	Test/Inspect/Clean
GAS HOSES/OUTLETS	Test/Inspect	Test/Inspect	Test/Inspect	Test/Inspect	Test/Inspect	Test/Inspect	Test/Inspect	Test/Inspect	Test/Inspect
LOCKS	Test/Inspect/Lubricate	Test/Inspect/Lubricate	Test/Inspect/Lubricate	Test/Inspect/Lubricate	Test/Inspect/Clean	Test/Inspect/Lubricate	Test/Inspect/Lubricate	Test/Inspect/Lubricate	Test/Inspect/Clean
HINGES	Test/Inspect/Lubricate	Test/Inspect	Test/Inspect/Lubricate	Test/Inspect	Test/Inspect/Lubricate	Test/Inspect	Test/Inspect/Lubricate	Test/Inspect	Test/Inspect/Lubricate
SEALS	Inspect/Clean	Inspect/Clean	Inspect/Clean	Inspect/Clean	Inspect/Clean	Inspect/Clean	Inspect/Clean	Inspect/Clean	Inspect/Clean
BRAKE CABLE	Inspect/Adjust	Inspect/Adjust	Inspect/Adjust	Inspect/Adjust	Inspect/Adjust/Lubricate	Inspect/Adjust	Inspect/Adjust	Inspect/Adjust	Inspect/Adjust/Lubricate
BRAKE LININGS	Inspect/Adjust	Inspect/Adjust	Inspect/Adjust	Inspect/Adjust	Inspect/Adjust/Clean	Inspect/Adjust	Inspect/Adjust	Inspect/Adjust	Inspect/Adjust/Clean
CHASSIS LUBE	Inspect	Inspect	Inspect	Inspect	Inspect/Lubricate	Inspect	Inspect	Inspect	Inspect/Lubricate
HITCH	Test/Inspect	Test/Inspect	Test/Inspect	Test/Inspect	Test/Inspect/Lubricate	Test/Inspect	Test/Inspect	Test/Inspect	Test/Inspect/Lubricate
JOCKEY WHEEL	Test/Inspect	Test/Inspect	Test/Inspect	Test/Inspect	Test/Inspect	Test/Inspect	Test/Inspect	Test/Inspect	Test/Inspect
STABILISER LEGS	Test/Inspect	Test/Inspect	Test/Inspect/Lubricate	Test/Inspect	Test/Inspect	Test/Inspect	Test/Inspect/Lubricate	Test/Inspect	Test/Inspect
WINCHES	Test/Inspect	Test/Inspect	Test/Inspect	Test/Inspect	Test/Inspect/Clean	Test/Inspect	Test/Inspect	Test/Inspect	Test/Inspect/Clean
SUSPENSION BUSHES	Inspect	Inspect	Inspect	Inspect	Inspect/Lubricate	Inspect	Inspect	Inspect	Inspect/Lubricate
WHEEL ALIGNMENT	Inspect/Adjust	Inspect	Inspect	Inspect	Inspect/Adjust	Inspect	Inspect	Inspect	Inspect/Adjust
WHEEL BEARINGS	Inspect/Adjust	Inspect/Adjust	Inspect/Adjust	Inspect/Adjust	Inspect/Adjust	Inspect/Adjust	Inspect/Adjust	Inspect/Adjust	Inspect/Adjust/Replace
WHEEL NUTS	Inspect/Adjust	Inspect	Inspect/Adjust	Inspect	Inspect/Adjust	Inspect	Inspect/Adjust	Inspect	Inspect/Adjust
TYRES	Inspect	Inspect	Inspect	Inspect	Inspect	Inspect	Inspect	Inspect	Inspect
TYRE PRESSURE	Adjust	Adjust	Adjust	Adjust	Adjust	Adjust	Adjust	Adjust	Adjust
GAS STRUTS	Test/Inspect/Lubricate	Test/Inspect	Test/Inspect	Test/Inspect	Test/Inspect/Lubricate	Test/Inspect	Test/Inspect	Test/Inspect	Test/Inspect/Lubricate
SHOCK ABSORBERS	Test/Inspect	Test/Inspect	Test/Inspect	Test/Inspect	Test/Inspect	Test/Inspect	Test/Inspect	Test/Inspect	Test/Inspect
FRIDGE FAN FILTER (X2)	Inspect/Clean	Inspect/Clean	Inspect/Clean	Inspect/Clean	Inspect/Clean	Inspect/Clean	Inspect/Clean	Inspect/Clean	Inspect/Clean
WATER TANKS	Test/Inspect	Test/Inspect	Test/Inspect/Clean	Test/Inspect	Test/Inspect/Clean	Test/Inspect	Test/Inspect/Clean	Test/Inspect	Test/Inspect/Clean